

# **Installation Manual**

---

## **1961-75 Jaguar XKE E-TYPE**

DOCUMENT #RA-1-1018

*Right Hand Drive*

©2017 Classic Auto Air / 01.17







# ***Congratulations...***

**You have just purchased the highest quality, best performing A/C system ever designed for your 61-75 Jaguar XKE E-Type.**

To obtain the high level of performance and dependability our systems are known for, please pay close attention to the following instructions. Our installation steps and procedures are derived from a long history of research and development and the combined experience achieved thru thousands of successful installations (and feedback from customers like you). Please remember that our #1 goal is that you'll have a successful installation and a system that performs at a very high level for many years to come.

Before starting, read the instructions carefully, from beginning to end, and follow the proper sequence. On the next page you'll find a safety and general checklist that you should read before starting your installation.

Again, thank you from our entire staff.



## Check List, Pre-Installation:

- Before beginning the installation check the shipping box for the correct components. YOUR BOXED UNIT INCLUDES A LIST OF MAJOR COMPONENTS AND A LIST OF BAGGED PARTS. We have a 5 stage check process to make sure you have everything you'll need.
- If your vehicle has been or is being modified, some procedures will need to be adjusted to fit your particular application.**
- A basic cleaning of the engine compartment and interior before beginning will make things go more smoothly.
- Check condition of engine mounts. Excessive engine movement can damage hoses to A/C and/or heater.
- Before starting, check vehicle interior electrical functions (interior lights, radio, horn, etc). Make a note of anything that does not work as it's supposed to. During the installation you might find the opportunity to repair or upgrade non-working or out of date components. When you're ready to start the installation, **DISCONNECT THE BATTERY FIRST.**
- SAFETY FIRST: Wear eye protection while drilling/cutting, deburr sharp edges, and never get in a hurry or force a part.
- Tools: Your installation only requires the basic tools everyone has in their garage, nothing exotic or specific to A/C or Heat equipment.

## Procedures, During Installation:

- Fittings: Use one or two drops of mineral oil (supplied with your kit) on ALL rubber o-rings, threads and rear of bump for o-ring where female nut rides. Do not use thread tape or sealants.
- Measure twice (or more), cut once
- Should you have any technical questions, or feel you have defective components (or missing items), call us immediately, we will be glad to assist you. Our toll-free number is listed on every page, we're here to help!**

***YOU CAN NOW BEGIN THE INSTALLATION...***

## A Basic Overview of Automotive A/C....

- 1 Evaporator with Blower Fan** In order to remove the heat from the air in the vehicle, the A/C evaporator allows the refrigerant to absorb the heat from the air passing over it. The blower fan moves cool air out into the car interior.
- 2 Compressor** The compressor pumps and circulates the refrigerant through the system.
- 3 Condenser** The condenser is a heat exchanger mounted at the front of the vehicle. Heat drawn out of the interior of the car is expelled here.
- 4 Receiver/Drier** The drier not only dries refrigerant, it also filters the refrigerant and stores it under certain operating conditions.
- 5 High Pressure Switch** A pressure switch is used to shut down the system if high or low pressure is detected, basically it acts as a safety switch.

The air conditioning system in your car is comprised of a compressor, condenser, expansion valve, receiver/drier, and evaporator. Refrigerant (also known as Freon) is compressed in the compressor. In the condenser, gas is cooled to a liquid state and travels to the expansion valve. As the liquid refrigerant goes through the expansion valve it rapidly cools in the evaporator. A fan blows over the evaporator and cools the air that blows out your vents.

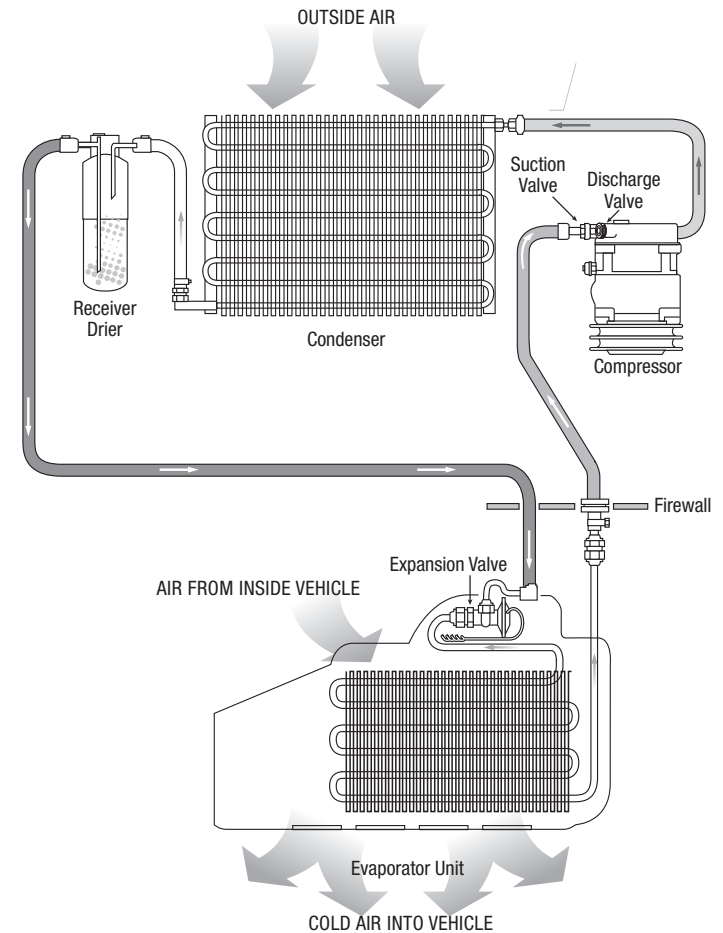

**Handle Evaporator Carefully It Can Be Bent In the Middle.**

The Evaporator assembly “mimics” the original S-2 system in appearance only- it is 3 to 4 times more efficient! Carefully set the unit inside the car to plan where the mounting brackets, A/C hose Firewall entry points, drain hoses and wiring will be attached. On Series 1 cars, the Evaporator will be close to the lower part of the Dash.

The “belly” surface on the bottom of the evaporator must be biased down toward the car front so condensation will drain into the drainage sumps! That will leave the bottom of the fan/motor housing at a much steeper angle! There are two (EEV1 & EEV2) slotted custom brackets enclosed that attach the Evaporator to the front, lower lip of the dashboard. Attach the long slot of the bracket to the side of the Evaporator and hand-tighten with the enclosed ¼ x ½” bolts and washers (there are 3 holes) choose the one that seems to work the best with the bracket and angle of the dashboard lip. The face of the Evaporator unit should be forward of the Right and Left Dashboard panels. The Custom Bracket short slot end will attach to the top of the dashboard lip with the ¼ x ½” Bolt, Nut & Washers- the Drivers side should be placed first, due to the limited lip space.



The right side can then be mocked up. Try brackets on opposite sides if alignment is wrong. When you are sure of the spacing and clearances of hoses, wires, etc., drill a hole in the lip to accept the ¼ X ½” Bolt, Nut and Washer, being sure to allow for bracket adjustment (center of the bracket slot). HB0001C evaporator bracket will be attached to the right side by the motor and housing and should be attached to the Dash Brace above it. All of these brackets are adjustable to allow you to position the Unit correctly. The hoses going to the Evaporator have extra length to be routed through the L/S Pedal Box Blanking Cover using the enclosed Grommets for chafe protection.

Drill (1) ½” hole on each side of the center Transmission hump for the Drain Hose fittings to be attached by epoxy and the drain hoses from the Evaporator connected to them. Make sure the drain holes are away from foot activity and will properly drain under the car! Match the Drain hole measurement spread on the rear of the unit. The A/C Hoses should be connected before permanently mounting the Evaporator.



The wires on the unit are marked for location- choose an already existing hole in the firewall to feed the long blue wire through and connect to one end of the Drier Hi-Lo Switch harness. The other end of the Drier Harness connects to the compressor with the enclosed wire and connector. Mount the circuit breaker in a remote location and attach the black wire from the main harness to the “Bat” post. Take the loose black wire and attach it to the “Aux” side of the Circuit Breaker and the other end to a “switched” ignition source (key turns A/C on & off). The “loose” wire on the motor is the Ground- attach to a good Body grounding source. With the engine not running and the ignition on, there should be an audible compressor “click” when the fan and temp switches are on. The Blower should operate in all 3 speeds- if not, there is a wiring problem. Attach the Relay wire to the original Fan relay, allowing the Fan(s) to come on when the A/C switch is turned on.





The Multi-Flow Condenser included in this kit can be installed with the Custom brackets and hardware provided, fittings facing left (small fitting on the bottom). Bend or shape Brackets to fit your Radiator mounting, keeping the Condenser Biased to the Right side to leave room for the fitting connections. Keep the condenser at least 1” from the radiator, and to the right (to avoid Hood Baffle interference) so the heat from either unit will not “feed” off each other. Be sure all air possible will be forced through the condenser!



The Drier will go next to the Brake and Clutch Reservoir (which may need to be moved slightly) with the “in” toward the front of the car. Connect the “live” Compressor wire to one end of the Drier Harness and the new Wiring Harness long blue wire to the other end of the Drier Harness with the enclosed connectors. This switch will shut the Compressor off if too much, or too little pressure is in the system.



The Kit has 2 brackets- The rear part is mounted to the inverted 5/16" Head stud that is replaced with the enclosed one. Do Not tighten yet! The long Bracket enclosed will be attached to the upper outermost bolt holes on the timing chain cover (just below the Head-see picture) with the enclosed 5/16" bolts- leave these hand tight also! You should now be able to mount the RA Compressor with the enclosed 3/8" bolts, nuts & washers with the bolt heads against the compressor ears. Tighten the Compressor bolts first, then all the other bolts that were left loose. A new belt is included with the Back Idler Pulley.



**REMOVE COVERS ONLY AT CONNECTION TIME AND O-RINGS MUST BE USED  
AND LUBRICATED ON EACH HOSE CONNECTION!!**

There are 4 A/C hoses with your kit. There are 2 small hoses (#6 liquid hoses)-RA-00007-03 is attached between the evaporator (Straight) and the rear drier fitting (90°). RA-00002-07 hose will attach between the Condenser (90°) and the T-Fitting (45° and the Hi-Lo Switch Fitting mounts to T-Fitting) connected to the Drier. RA-00002-11 hose (#8 discharge hose) goes between the condenser (90°) and the compressor (90° w/ Svc Port). RA-00007-04 (#10 suction hose) attaches to the Evaporator (Straight) and the Compressor (90° w/ Svc Port). Attach hose fittings hand tight, making sure the Service Ports are on the Compressor, "O" Rings are installed, and everything is clear and Aligned before Fully Tightening!!

Hose Insulation: After hose installation, cut included insulation to size for hose protection against extreme heat (exhaust manifold), and slit lengthwise to slip over hose. Use enclosed Aluminum Tape to cover slit lengthwise, which should be away from heat source.



The Bracket replaces the Alternator Bracket, and comes in two pieces. The flat piece mounts to the Left side of the Water pump, do not tighten! The 90 deg piece gets mounted to the old Alternator Engine Bosses, and both pieces will be connected to each other. Once the 2 pieces are tightened down, it will be necessary to drill a hole(s) in both pieces where they meet and install Bolts, washers and nuts to firm up the bracket. Mount the Classic Auto Air Compressor to the main bracket before installing the Compressor Hose fittings, and install Bracket in place of the stock Alternator Bracket. This is a new, upgrade Bracket for this car and some adjustments may have to be made for correct belt alignment. The small Adjustment arm goes on the R/F bottom mount of the Compressor- when mounted; adjust the Compressor so it is almost touching the Engine. The Compressor Front Top Foot fits in front of the tab under the Bracket using spacers if needed. Additional spacers may need to be added or subtracted. The Alternator Front lower Foot mounts in front/top of the Bracket using 1/16" Spacer. The rear has a spacer between the Alternator and the Bracket tab. This would also be the time to install the Heat shield on the exhaust manifold.

Alternator Connections: For originality, Open the Regulator by removing Pop Rivets (replace w/ small bolt/nut). Make a permanent connection for the heavy Brown Wire by wedging the Cut-out relay closed (the relay with the 2 white wires attached). Alternative Diagram at Bottom!!

To connect the Red Ignition Light, disconnect the separate yellow and green wires from the regulator and connect them together. You may now replace the cover and tuck the exposed wires behind the regulator.

The Large Diameter wire from the Alternator will go to the Large Brown wire (Direct Battery), and the smaller one will go to the green field wire (switched Ignition source). This is a very tight installation, Please Check all Hood, accessory and Wiring Harness clearances!



**Remove covers only at connection time and properly lubricate "o" rings on each hose connection!**

There are 4 A/C hoses with your kit. Install "O" rings, using the enclosed "O" Ring Lube, before installing hoses!! There are 2 small hoses (#6 liquid hoses)-RA-00007-01 is attached between the evaporator (Straight) and the rear drier fitting (90°). RA-00002-07 will attach between the Condenser (90°) and the T-Fitting (45° and the Hi-Lo Switch mounts to the T-Fitting) that's connected to the Drier. RA-00002-11 (#8 discharge hose) goes between the condenser (90°) and the compressor (90° w/ Svc Port). RA-00007-02 (#10 Suction) attaches to the Evaporator (Straight) and the Compressor (90° w/ Svc Port). Attach hose fittings hand tight, making sure the Service Ports are on the Compressor, "O" Rings are installed, and everything is clear and aligned before fully tightening!! After hose installation, cut included insulation to size for hose protection against extreme heat (exhaust manifold), and slit lengthwise to slip over hose. Use enclosed Aluminum Tape to cover slit lengthwise, which should be away from heat source.



**We have found some differences in Crank Pulley distance!**

Before installing disconnect battery, remove radiator tank, alternator, belt and OEM mount and discard mount and belt.

Install compressor cradle mount on the main mount using (4) 5/16-18 x 1" Bolts, Lock Washers and Nuts.

Install Compressor/Alternator Mounting bracket using (5) 5/16-24 x 3" bolts and (1) 15/16" Spacer with lock washers in front water pump bolt holes and (2) 7/16-20 x 1 1/2" bolts, lock washers and 7/16" spacers in side engine bosses. Install 1/2-20 x 1" Bolt and Star Washer through idler pad. Tighten all bolts securely. Note; Vehicles which have numbers cast in the water pump must be ground off to allow proper bolt alignment.

Attach compressor to cradle mount using (4) 3/8-16 x 1 1/2" bolts, flat washers, lock washers and nuts. Tighten down.

Attach the Alternator to the mount using (1) 5/16-18 x 1 1/2" bolt, lock washer, 9/16" spacer (for alignment) and nut through the front ear and repeat for rear ear. Attach the adjusting arm to mount using 5/16-18 x 1" bolt, flat washer, lock washer and nut.

Connect slotted end to Alternator using 5/16-18 x 1 1/2" bolt, 1/4" spacer, 7/16" flat washer, lock washer and nut. Do not tighten at this time.

Attach lower idler pulley to mount using 3/8-16 x 1 3/4" bolt, bushing, 11/32" spacer, lock washer and nut. Tighten securely.

Attach upper idler pulley to the eccentric using idler bolt and 7/16" flat washer. Install this assembly on the mount using 1/2-20 x 1" bolt previously installed and do not tighten at this time.

Thread compressor belt around crank pulley, idler pulley, clutch and water pump. Adjust to proper tension with the eccentric and tighten 1/2" bolt. Thread Alternator Belt around clutch, idler pulley and alternator, adjust to proper tension. Relocate Radiator Tank and reconnect battery.

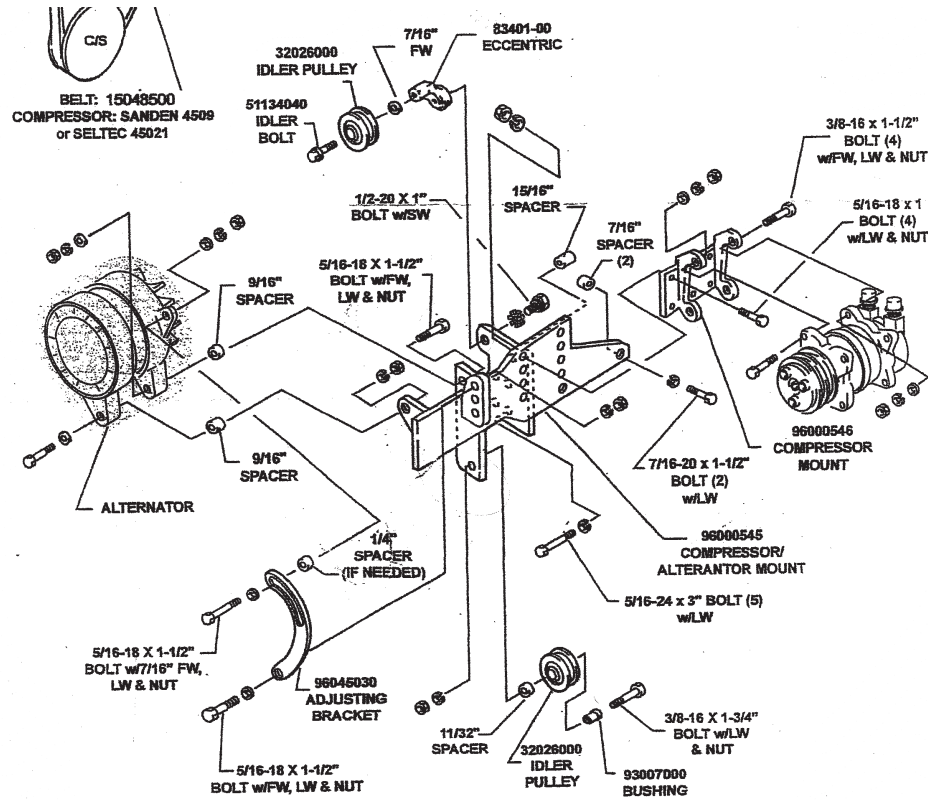

Before mounting the Compressor, the enclosed bracket(s) must be installed (instructions in box). After installing the bracket(s) would also be the time to install the Heat Shield on the exhaust manifold, which will have to be bent, formed and cut as necessary to clear the compressor and /or bracket. On some cars, it may be necessary to remove L/F Compressor "ear" to allow extra clearance to the car Frame!





**Remove covers only at connection time and O-rings must be used and lubricated on each hose connection!!**

There are 4 A/C hoses with your kit. Install "O" rings before installing hoses!! There are 2 small hoses (#6 liquid hoses)-RA-00007-05 will attach between the evaporator (90°) and the rear drier fitting (90°). RA-00002-07 will attach between the Condenser (90°) and the In-Line Fitting on Drier (45° fitting). RA-00002-09 (#8 discharge hose) will attach between the condenser and the compressor (both 90°). RA-00007-06 (#10 suction hose) will attach between the Evaporator (90°) and the Compressor (straight). Between the hoses and the Compressor you will have the two 90° Adapters w/ Service Port. Attach hose fittings hand tight, making sure the Service Ports are on the Compressor, "O" Rings are installed, and everything is clear and aligned before fully tightening!!

Hose Insulation: After hose installation, cut insulation to size for hose protection against extreme heat (exhaust manifold), and cut lengthwise to slip over hose. Use enclosed Aluminum Tape to cover slit lengthwise, which should be away from heat source.



We have found some differences in Crank Pulley distance!

Before mounting the Compressor, the enclosed bracket(s) must be installed-The large Front section will mount to the front of the "V" valley. The rear will mount to the valley cover, in the rear, with the original bolts and line up with the Compressor mounts. See pictures.



**Remove covers only at connection time and O-Rings must be used and lubricated on each hose connection!!**

**Many of these fittings were not installed so the hose length can be shortened, if necessary!**

There are 4 A/C hoses with your kit. Install "O" rings before installing hoses!! There are 2 small diameter hoses (#6 liquid hoses) RA-00007-07 will attach between the evaporator and the rear drier fitting. RA-00002-14 will attach between the Condenser (90°) and the T-Fitting (straight) attached to the Drier. RA-00007-08 (#8 discharge hose) goes between the condenser and the compressor. RA-00007-09 (#10 suction hose) attaches to the Evaporator and the Compressor. Compressor end fittings will have the two 90° Service Port fittings. Attach hose fittings hand tight, making sure the Service Ports are on the Compressor, "O" Rings are installed, and everything is Clear and Aligned Before Fully Tightening!!

Upon Assembly Completion, the System will need to be evacuated for 30-45 minutes and then charge with approximately 12-16 ounces of R134A Refrigerant! (Compressor is shipped with correct oil capacity)



The Compressor comes with the correct Refrigerant oil from the factory. DO NOT ADD OIL! Evacuate the system for a minimum of 30-45 minutes before charging. Longer if possible. This will remove any moisture and reveal any small leaks. After evacuating, the initial R134A charge will be 12-14 oz. and the total will depend upon the outside temperature. At 95-100°F, you can expect 225-250 psi high side and 25-30 psi low side at 1000-1200 RPM with a strong Fan blowing across the Condenser!

It will be necessary to remove the Radiator and Fan Blade. Remove the Bolt (see pictures). The back of the belt rides on the idler pulley and goes down to the Crankshaft on the Right side and comes up & over the Water pump pulley on the Left side, to the Compressor, down to the Generator/Alternator to make the complete loop.

**REVERSE BRACKET DIRECTION FOR ADDITIONAL CLEARANCE!**

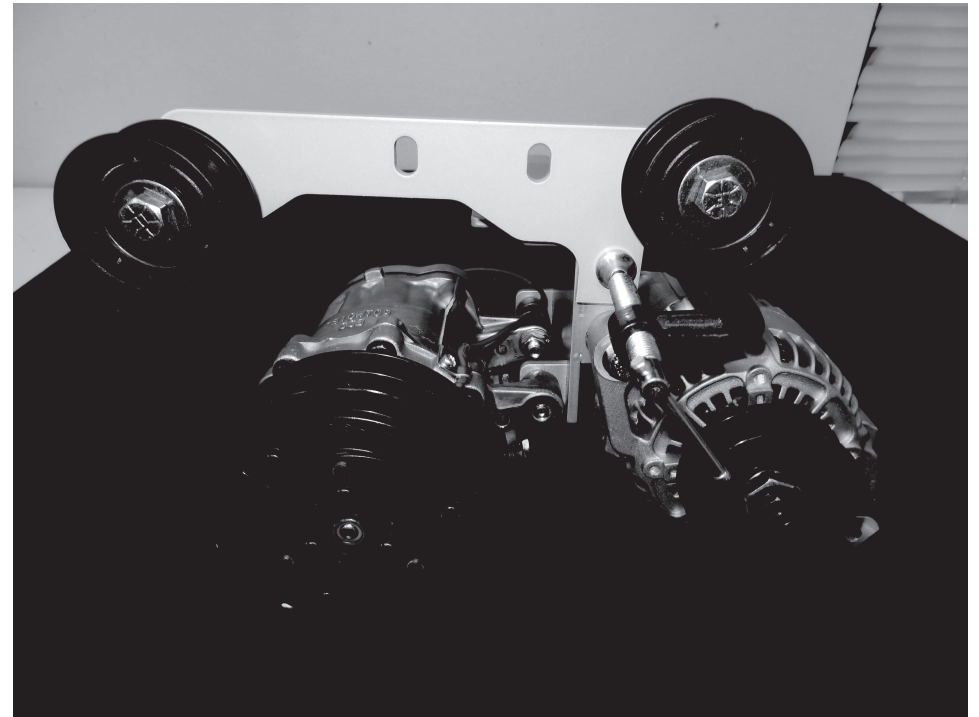

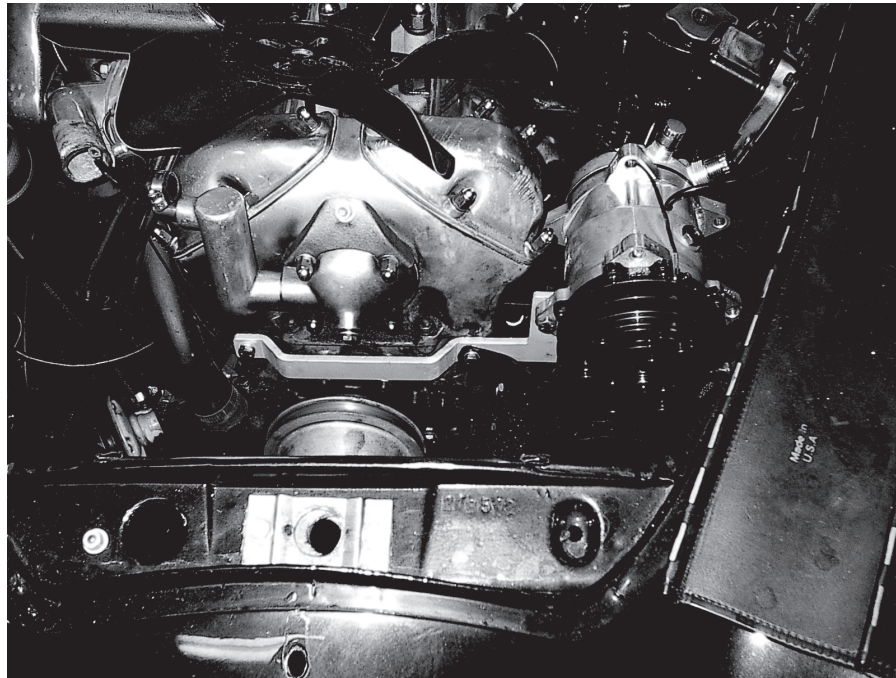

## New A/C System Preparation... A MUST READ!

Please read thru these procedures before completing this new A/C system charging operation.

**A licensed A/C technician should be utilized for these procedures to insure that your new system will perform at it's peak, and that your compressor will not be damaged.**

- 1) Evacuate the system for 45 minutes (minimum).
- 2) **Your new compressor **MUST** be hand-turned 15-20 revolutions before and after charging with liquid. Failure to do this may cause the reed valves to become damaged** (this damage is NOT covered by your warranty).
- 3) Your new system requires 134a refrigerant. It will require 1.5 lbs (or 24 oz).
- 4) Your new compressor comes charged with oil - NO additional oil is needed.
- 5) Insure that the new belt is tight.
- 6) **DO NOT CHARGE SYSTEM WITH LIQUID REFRIGERANT!**



**RECOMMENDED TEST CONDITIONS:** (After system has been fully charged and tested for basic operation)

- Determine the temperature outside of the car
- Connect gauges or service equipment to high/low charging ports
- Place blower fan switch on medium
- Close all doors and windows on vehicle
- Place shop fan directly in front of condenser
- Run engine idle up to approx. 1500 Rpm

**ACCEPTABLE OPERATING PRESSURE RANGES:**

1. HIGH-SIDE PRESSURES (150-275 PSI)
2. LOW-SIDE PRESSURES (10-25 PSI in a steady state)

Readings above are based on an ambient temperature of 90° with an adequate airflow on condenser

CENTERLINE OF THE OIL FILL BOLT

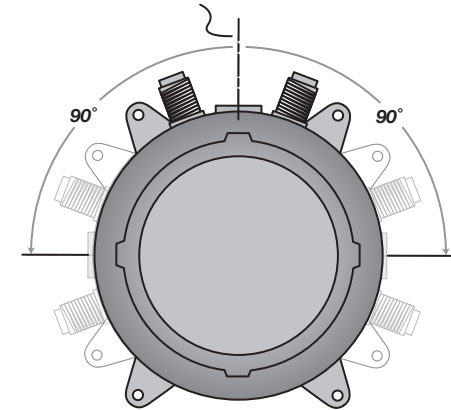

When mounting your compressor and/or adjusting the belt, Set compressor at 90 degrees.

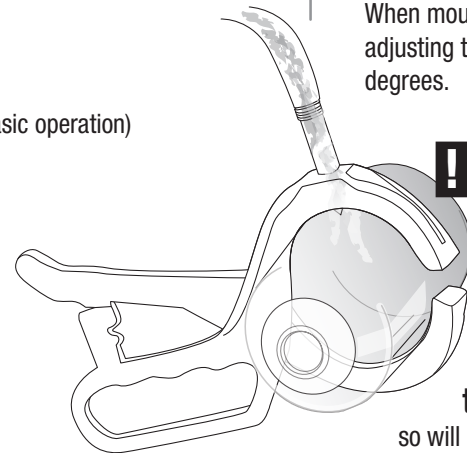

**Do NOT tilt, shake or turn refrigerant can upside-down OR use a charging station to install refrigerant while the engine is running.** Doing

so will direct liquid refrigerant into the compressor piston chamber, causing damage to reed valves and/or pistons and/or other components, as well as potentially seizing the compressor. Allow a minimum of 30 minutes for liquid to "boil off." You must hand turn the compressor hub (not the pulley) a minimum of 15 complete revolutions prior to starting the engine with the clutch engaged.



## TROUBLESHOOTING GUIDE

### TEST CONDITIONS USED TO DETERMINE SYSTEM OPERATION

(THESE TEST CONDITIONS WILL SIMULATE THE AFFECT OF DRIVING THE VEHICLE AND GIVE THE TECHNICIAN THE THREE CRITICAL READINGS THAT THEY WILL NEED TO DIAGNOSE ANY POTENTIAL PROBLEMS).

- B. CONNECT GAUGES OR SERVICE EQUIPMENT TO HIGH/LOW CHARGING PORTS.
- C. PLACE BLOWER FAN SWITCH ON MEDIUM.
- D. CLOSE ALL DOORS AND WINDOWS ON VEHICLE.
- E. PLACE SHOP FAN IN FRONT OF CONDENSER.
- F. RUN ENGINE IDLE UP TO 1500 RPM.

### ACCEPTABLE OPERATING PRESSURE RANGES (R134A TYPE)

1. HIGH-SIDE PRESSURES ( 150-275 PSI ) *\*Note- general rule of thumb is two times the ambient (daytime) temperature, plus 15-20%.*
2. LOW-SIDE PRESSURES ( 10-25 PSI in a steady state).

**CHARGE AS FOLLOWS: R134A = 24 OZ.**

**NO ADDITIONAL OIL IS NECESSARY IN OUR NEW COMPRESSORS.**

### TYPICAL PROBLEMS ENCOUNTERED IN CHARGING SYSTEMS

**NOISY COMPRESSOR.** A noisy compressor is generally caused by charging a compressor with liquid or overcharging

- A. If the system is overcharged both gauges will read abnormally high readings. This is causing a feedback pressure on the compressor causing it to rattle or shake from the increased cylinder head pressures. System must be evacuated and re-charged to exact weight specifications.
- B. **Heater control valve installation** - Installing the heater control valve in the incorrect hose. Usually when this occurs the system will cool at idle then start to warm up when raising the RPM's of the motor. **THE HEATER CONTROL IS A DIRECTIONAL VALVE; MAKE SURE THE WATER FLOW IS WITH THE DIRECTION OF THE ARROW.** As the engine heats up that water transfers the heat to the coil, thus overpowering the a/c coil. A leaking or faulty valve will

have a more pronounced affect on the unit's cooling ability. Installing the valve improperly (such as having the flow reversed) will also allow water to flow through, thus inhibiting cooling. Check for heat transfer by disconnecting hoses from the system completely. By running down the road with the hoses looped backed through the motor, you eliminate the possibility of heat transfer to the unit.

- C. **Evaporator freezing** - Freezing can occur both externally and internally on an evaporator core. External freeze up occurs when the coil cannot effectively displace the condensation on the outside fins and the water forms ice (the evaporator core resembles a block of solid ice), it restricts the flow of air that can pass through it, which gives the illusion of the air not functioning. The common cause of external freezing is the setting of the thermostat and the presence of high humidity in the passenger compartment. All door and window seals should be checked in the event of constant freeze-up. A thermostat is provided with all units to control the cycling of the compressor.
- D. **Internal freeze up** occurs when there is too much moisture inside the system. The symptoms of internal freeze up often surface after extended highway driving. The volume of air stays constant, but the temperature of the air gradually rises. When this freezing occurs the low side pressure will drop, eventually going into a vacuum. At this point, the system should be checked by a professional who will evacuate the system and the drier will have to be changed.
- E. **Inadequate airflow to condenser** - The condenser works best in front of the radiator with a large supply of fresh air. Abnormally high pressures will result from improper airflow. Check the airflow requirements by placing a large capacity fan in front of the condenser and running cool water over the surface. If the pressures drop significantly, this will indicate the need for better airflow.
- F. **Incorrect or inadequate condenser capacity** - Incorrect condenser capacity will cause abnormally high head pressures. A quick test that can be performed is to run cool water over the condenser while the system is operating, if the pressures decrease significantly, it is likely a airflow or capacity problem.
- G. **Expansion valve failure** - An expansion valve failure is generally caused by dirt or debris entering the system during assembly. If an expansion valve fails it will be indicated by abnormal gauge readings. A valve that is blocked will be indicated by high side that is unusually high, while the low side will be unusually low or may even go into a vacuum. A valve that is stuck open will be indicated by both the high and low pressures rising to unusually high readings, seeming to move toward equal readings on the gauges.
- H. **Restrictions in system** - A restriction in the cooling system will cause abnormal readings on the gauges. A high-side restriction ( between the compressor and the drier inlet ) will be indicated by the discharge gauges reading excessively high. These simple tests can be performed by a local shop and can help determine the extent of the systems problem.





## Trouble Shooting Your Classic Auto Air A/C System

**PROBLEM: system is not cooling properly**

**ISSUE: cold at idle, warmer when raising engine RPM's**

### Make sure the Water Valve is positioned correctly

The water valve is a directional valve and should be installed with the arrow pointing towards the water pump, it should be connected to the heater hose that runs from the heater core to the water pump. If the water valve is connected to the incorrect hose it allows water to circulate through the system via the heater core over powering the cooling effect of the A/C coil, (normally the air conditioning is functioning properly).

**Step 1:** Check placement of the water valve, correct if needed. (In some cases changing the location of the water valve may not fix the above problem.) Continue to next step.

**Step 2** If changing the location of the water valve does not rectify the issue, then possibly the water valve is permanently damaged and may need to be replaced. To check the integrity of the water valve completely remove the water hoses for the heater core and "loop" together. (This will remove the heater system completely from the possibilities) If the system now cools, replace the water valve

### **Verify Adequate Air Flow to Condenser**

For an air conditioning system to function properly there has to be adequate airflow across the condenser. The function of the condenser is to dissipate heat, without proper airflow your system will not cool correctly in the cabin of your vehicle.

**Step 1:** connect gauges to a/c hoses. The pressures should be: with the ambient temp is 90, low side pressures should be between 10-25 psi, high side pressures should be between 150-275 psi

**Step 2:** IF the low side pressures are normal and the high side pressures are high then there might be an airflow issue, continue to next step.

### **To test air flow to Condenser do the following three tests:**

1. Place a piece of paper on the condenser with the car in idle and see if paper is held in place.
2. With car in idle, attach gages, and place a large capacity fan in front of the condenser. What happens to the pressures?
3. With car still in idle and gages attached, pour water down the front of the condenser. What happens to the pressures?

If the paper is held in place you are at least getting some air flow. If the high side decreases during test 2 & 3 then your condenser is not getting enough air which is causing your system to not cool properly. To correct this issue you will need a more powerful mechanical fan.

### **Step 3: Confirm correct Refrigerant charge in System**

All of our systems should be charged with 24 oz or 1.5 lbs of R134A Refrigerant only. If overcharged you will need to evacuate the system and recharge with the correct amount.\*

### **What measurements mean:**

Low Temp and High Pressure seem to be equal...

You have a malfunctioning expansion valve that is stuck open.

High Side is extremely high and Low Side is extremely low (possibly into vacuum)...

There is a blockage in the system. Remove hoses and blow compressed air through in both directions. If pressures don't change its possible that your expansion valve is stuck closed and would have to be replaced.

### **\*Compressor Concerns:**

This is often misdiagnosed as a problem for the system not cooling properly. If you have a noisy compressor it is due to improper charging of refrigerant. An overcharged (more than 24 oz or 1.5 lbs R134A) compressor can cause rattling. If charged with pure liquid there is a high probability you have bent reed valves that are causing tapping sound.

